

KENWOOD

INSTRUCTION MANUAL



VHF FM TRANSCEIVER

TK-2180

UHF FM TRANSCEIVER

TK-3180

KENWOOD CORPORATION

© B62-1759-10 (K)
09 08 07 06 05 04 03 02 01

THANK YOU

We are grateful you chose **KENWOOD** for your land mobile radio applications. We believe this easy-to-use transceiver will provide dependable communications to keep personnel operating at peak efficiency.

KENWOOD transceivers incorporate the latest in advanced technology. As a result, we feel strongly that you will be pleased with the quality and features of this product.

MODELS COVERED BY THIS MANUAL

- TK-2180: VHF FM Transceiver
- TK-3180: UHF FM Transceiver

NOTICES TO THE USER

- ◆ Government law prohibits the operation of unlicensed radio transmitters within the territories under government control.
- ◆ Illegal operation is punishable by fine and/or imprisonment.
- ◆ Refer service to qualified technicians only.

SAFETY: It is important that the operator is aware of and understands hazards common to the operation of any transceiver.



WARNING

EXPLOSIVE ATMOSPHERES (GASES, DUST, FUMES, etc.)

Turn off your transceiver while taking on fuel, or while parked in gasoline service stations.

PRECAUTIONS

Observe the following precautions to prevent fire, personal injury, and transceiver damage.

- Do not modify this transceiver for any reason.
- Do not expose the transceiver to long periods of direct sunlight, nor place it close to heating appliances.
- Do not place the transceiver in excessively dusty, humid, or wet areas, nor on unstable surfaces.
- If an abnormal odor or smoke is detected coming from the transceiver, immediately switch OFF the power and remove the battery pack from the transceiver. Contact your **KENWOOD** dealer.

One or more of the following statements may be applicable:

FCC WARNING

This equipment generates or uses radio frequency energy. Changes or modifications to this equipment may cause harmful interference unless the modifications are expressly approved in the instruction manual. The user could lose the authority to operate this equipment if an unauthorized change or modification is made.

INFORMATION TO THE DIGITAL DEVICE USER REQUIRED BY THE FCC

This equipment has been tested and found to comply with the limits for a Class B digital device, pursuant to Part 15 of the FCC Rules. These limits are designed to provide reasonable protection against harmful interference in a residential installation.

This equipment generates, uses and can generate radio frequency energy and, if not installed and used in accordance with the instructions, may cause harmful interference to radio communications. However, there is no guarantee that the interference will not occur in a particular installation. If this equipment does cause harmful interference to radio or television reception, which can be determined by turning the equipment off and on, the user is encouraged to try to correct the interference by one or more of the following measures:

- Reorient or relocate the receiving antenna.
- Increase the separation between the equipment and receiver.
- Connect the equipment to an outlet on a circuit different from that to which the receiver is connected.
- Consult the dealer for technical assistance.

Attention (U.S.A. Only):



The RBRC Recycle seal found on **KENWOOD** nickel-cadmium (Ni-Cd) battery packs indicates **KENWOOD's** voluntary participation in an industry program to collect and recycle Ni-Cd batteries after their operating life has expired. The RBRC program is an alternative to disposing Ni-Cd batteries with your regular refuse or in municipal waste streams, which is illegal in some areas.

For information on Ni-Cd battery recycling in your area, call (toll free) 1-800-8-BATTERY (1-800-822-8837).

KENWOOD's involvement in this program is part of our commitment to preserve our environment and conserve our natural resources.



The RBRC Recycle seal found on **KENWOOD** nickel metal hydride (Ni-MH) battery packs indicates **KENWOOD's** voluntary participation in an industry program to collect and recycle Ni-MH batteries after their operating life has expired. The RBRC program is an alternative to disposing Ni-MH batteries with your regular refuse or in municipal waste streams, which is illegal in some areas.

For information on Ni-MH battery recycling in your area, call (toll free) 1-800-8-BATTERY (1-800-822-8837).

KENWOOD's involvement in this program is part of our commitment to preserve our environment and conserve our natural resources.



The RBRC Recycle seal found on **KENWOOD** lithium-ion (Li-ion) battery packs indicates **KENWOOD's** voluntary participation in an industry program to collect and recycle Li-ion batteries after their operating life has expired. The RBRC program is an alternative to disposing Li-ion batteries with your regular refuse or in municipal waste streams, which is illegal in some areas.

For information on Li-ion battery recycling in your area, call (toll free) 1-800-8-BATTERY (1-800-822-8837).

KENWOOD's involvement in this program is part of our commitment to preserve our environment and conserve our natural resources.

CONTENTS

UNPACKING AND CHECKING EQUIPMENT	1
SUPPLIED ACCESSORIES	1
PREPARATION	2
BATTERY PACK PRECAUTIONS	2
INSTALLING/ REMOVING THE (OPTIONAL) BATTERY PACK	7
INSTALLING THE (OPTIONAL) ANTENNA	8
INSTALLING THE BELT CLIP	8
INSTALLING THE COVER OVER THE UNIVERSAL CONNECTOR	9
INSTALLING THE (OPTIONAL KMC-25) SPEAKER/ MICROPHONE	9
GETTING ACQUAINTED	10
DISPLAY	13
PROGRAMMABLE FUNCTIONS	15
OPERATING BASICS	17
OVERVIEW	17
SWITCHING POWER ON/ OFF	17
ADJUSTING THE VOLUME	18
SELECTING A ZONE AND CHANNEL/ GROUP ID	18
TRUNKING ZONES	19
PLACING A DISPATCH CALL	19
RECEIVING A DISPATCH CALL	19
PLACING A TELEPHONE CALL	20
RECEIVING A TELEPHONE CALL	20
CONVENTIONAL ZONES	21
TRANSMITTING	21
RECEIVING	21
QUIET TALK (QT)/ DIGITAL QUIET TALK (DQT)	21
2-TONE SIGNALING	22
OPERATOR SELECTABLE TONE (OST)	23
VOICE OPERATED TRANSMISSION (VOX)	23
SCAN	25
ADD TO SCAN	26
SCAN REVERT	26
PRIORITY SCAN	27
GROUP SCAN	27

FLEETSYNC: ALPHANUMERIC 2-WAY PAGING FUNCTION	28
SECALL (SELECTIVE CALLING)	28
STATUS MESSAGE	29
SHORT MESSAGES	31
LONG MESSAGES	31
DTMF (DUAL TONE MULTI FREQUENCY) CALLS	32
MANUAL DIALING (KEYPAD MODELS ONLY)	32
STORE AND SEND	33
AUTODIAL	33
REDIAL (KEYPAD MODELS ONLY)	35
CONNECT/ DISCONNECT IDs (KEYPAD MODELS ONLY)	35
DTMF SIGNALING	36
STUN	36
EMERGENCY CALLS	37
ADVANCED OPERATIONS	38
SELECTING A TRANSMIT POWER	38
TALK AROUND	38
MONITOR/ SQUELCH OFF	39
KEY LOCK	40
SCRAMBLER	40
CLOCK	41
BACKLIGHT	41
BACKGROUND OPERATIONS	42
TIME-OUT TIMER (TOT)	42
BUSY CHANNEL LOCKOUT (BCL)	42
BATTERY SAVER	43
BATTERY POWER INDICATOR	43
SIGNAL STRENGTH INDICATOR	43
BEGINNING/ END OF TRANSMIT SIGNAL	44
VGS-1 OPTIONAL VOICE GUIDE & STORAGE UNIT	45
VOICE RECORDER	45
VOICE GUIDE	45

UNPACKING AND CHECKING EQUIPMENT

Note: The following unpacking instructions are for use by your **KENWOOD** dealer, an authorized **KENWOOD** service facility, or the factory.

Carefully unpack the transceiver. We recommend that you identify the items listed in the following table before discarding the packing material. If any items are missing or have been damaged during shipment, file a claim with the carrier immediately.

SUPPLIED ACCESSORIES

Item	Part Number	Quantity
Belt clip	J29-0710-XX	1
Screw for belt clip	N30-3008-XX	2
Univeral connector cap	B09-0625-XX	1
Screw for connector cap	N08-0548-XX	1
Instruction manual	B62-1759-XX	1

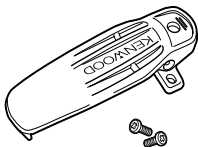

Belt clip + screws

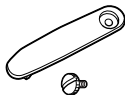

Univeral connector cap + screw

PREPARATION

BATTERY PACK PRECAUTIONS



CAUTION

- ◆ Do not recharge the battery pack if it is already fully charged. Doing so may cause the life of the battery pack to shorten or the battery pack may be damaged.
- ◆ After recharging the battery pack, disconnect it from the charger. If the charger power is reset (turned ON after being turned OFF), recharging will start again and the battery pack will become overcharged.
- ◆ Do not use the transceiver while charging the battery pack. We recommend you switch the transceiver power OFF while charging is taking place.
- ◆ Do not charge the battery pack when the battery pack or transceiver is wet, to avoid the risk of fire or damage. Wipe the water from the battery pack or transceiver using a dry cloth before charging.
- ◆ Do not short the battery terminals or dispose of the battery by fire.
- ◆ Never attempt to remove the casing from the battery pack.

■ CHARGING THE BATTERY PACK

For charging procedures, refer to the KSC-32 Instruction Manual.

Information concerning the (optional) Li-ion battery pack:

The battery pack includes flammable objects such as organic solvent. Mishandling may cause the battery to rupture producing flames or extreme heat, deteriorate, or cause other forms of damage to the battery. Please observe the following prohibitive matters.



DANGER

- **Do not disassemble or reconstruct battery!**

The battery pack has a safety function and protection circuit to avoid danger. If they suffer serious damage, the battery may generate heat or smoke, rupture, or burst into flame.

- **Do not short-circuit the battery!**

Do not join the + and – terminals using any form of metal (such as a paper clip or wire). Do not carry or store the battery pack in containers holding metal objects (such as wires, chain-necklace or hairpins). If the battery pack is short-circuited, excessive current will flow and the battery may generate heat or smoke, rupture, or burst into flame. It will also cause metal objects to heat up.

- **Do not incinerate or apply heat to the battery!**

If the insulator is melted, the gas release vent or safety function is damaged, or the electrolyte is ignited, the battery may generate heat or smoke, rupture, or burst into flame.

- **Do not use or leave the battery near fires, stoves, or other heat generators (areas reaching over 176°F/ 80°C)!**

If the polymer separator is melted due to high temperature, an internal short-circuit may occur in the individual cells and the battery may generate heat or smoke, rupture, or burst into flame.

- **Do not immerse the battery in water or get it wet by other means!**

If the battery's protection circuit is damaged, the battery may charge at extreme current (or voltage) and an abnormal chemical reaction may occur. The battery may generate heat or smoke, rupture, or burst into flame.

- **Do not charge the battery near fires or under direct sunlight!**

If the battery's protection circuit is damaged, the battery may charge at extreme current (or voltage) and an abnormal chemical reaction may occur. The battery may generate heat or smoke, rupture, or burst into flame.

- **Use only the specified charger and observe charging requirements!**

If the battery is charged in unspecified conditions (under high temperature over the regulated value, excessive high voltage or current over regulated value, or with a remodelled charger), it may overcharge or an abnormal chemical reaction may occur. The battery may generate heat or smoke, rupture, or burst into flame.

- **Do not pierce the battery with any object, strike it with an instrument, or step on it!**

This may break or deform the battery, causing a short-circuited. The battery may generate heat or smoke, rupture, or burst into flame.

- **Do not jar or throw the battery!**

An impact may cause the battery to leak, generate heat or smoke, rupture, and/or burst into flame. If the battery's protection circuit is damaged, the battery may charge at an abnormal current (or voltage), and an abnormal chemical reaction may occur. The battery may generate heat or smoke, rupture, or burst into flame.

- **Do not use the battery pack if it is damaged in any way!**

The battery may generate heat or smoke, rupture, or burst into flame.

- **Do not solder directly onto the battery!**

If the insulator is melted or the gas release vent or safety function is damaged, the battery may generate heat or smoke, rupture, or burst into flame.

- **Do not reverse the battery polarity (and terminals)!**

When charging a reversed battery, an abnormal chemical reaction may occur. In some cases, an unexpected large amount of current may flow upon discharging. The battery may generate heat or smoke, rupture, or burst into flame.

- **Do not reverse-charge or reverse-connect the battery!**

The battery pack has positive and negative poles. If the battery pack does not smoothly connect with a charger or operating equipment, do not force it; check the polarity of the battery. If the battery pack is reverse-connected to the charger, it will be reverse-charged and an abnormal chemical reaction may occur. The battery may generate heat or smoke, rupture, or burst into flame.

- **Do not touch a ruptured and leaking battery!**

If the electrolyte liquid from the battery gets into your eyes, wash your eyes out with fresh water as soon as possible, without rubbing your eyes. Go to the hospital immediately. If left untreated, it may cause eye-problems.

**WARNING**

- **Do not charge the battery for longer than the specified time!**

If the battery pack has not finished charging even after the regulated time has passed, stop it. The battery may generate heat or smoke, rupture, or burst into flame.

- **Do not place the battery pack into a microwave or high pressure container!**

The battery may generate heat or smoke, rupture, or burst into flame.

- **Keep ruptured and leaking battery packs away from fire!**

If the battery pack is leaking (or the battery emits a bad odor), immediately remove it from flammable areas. Electrolyte leaking from battery can easily catch on fire and may cause the battery to generate smoke or burst into flame.

- **Do not use an abnormal battery!**

If the battery pack emits a bad odor, appears to have different coloring, is deformed, or seems abnormal for any other reason, remove it from the charger or operating equipment and do not use it. The battery may generate heat or smoke, rupture, or burst into flame.

■ USING THE LI-ION BATTERY PACK

- Charge the battery pack before using it.
- To keep the battery discharge at a minimum, remove the battery pack from the equipment when it is not in use. Store the battery pack in a cool and dry location.
- When storing the battery pack for a long period:
 - 1 Remove the battery pack from the equipment.
 - 2 Discharge the battery pack, if possible.
 - 3 Store the battery pack in a cool (below 77°F/ 25°C) and dry location.

■ CHARACTERISTICS OF THE LI-ION BATTERY PACK

- As the battery pack is charged and discharged repeatedly, the battery capacity decreases.
- Even if the battery pack is unused, the battery pack degrades.
- It takes a longer time to charge the battery pack in cooler areas.
- The life of battery pack is shortened when it is charged and discharged in hotter areas. When the battery pack is stored in a hot location, the battery pack degrades quicker. Do not leave the battery pack in vehicles or near heating appliances.
- When the battery pack operating time becomes short, even if it is fully charged, replace the battery pack. Continuing to charge and discharge the battery pack may result in electrolyte leakage.

INSTALLING/ REMOVING THE (OPTIONAL) BATTERY PACK

- 1 Align the battery pack with the back of the transceiver, then press the battery pack and transceiver firmly together until the release latch clicks, locking it in place.

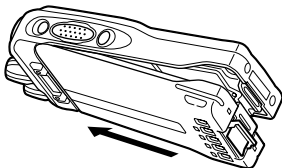

- 2 Flip the safety catch into place to prevent accidentally pressing the release latch and removing the battery.

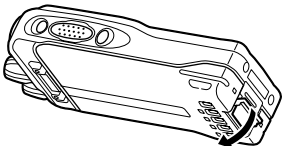

- 3 To remove the battery pack, lift the safety catch on the base of the transceiver, then press the release latch underneath the safety catch while pulling the battery pack away from the transceiver.

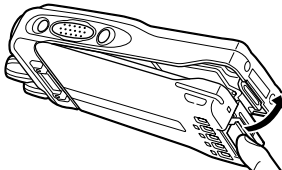

Note:

- ◆ To lift the battery pack safety catch, use a piece of hardened plastic or metal, such as a screwdriver, that is no more than 6 mm wide and 1 mm thick. It is imperative that you place the implement under only the lip of the safety catch so that you do not damage the release latch.
 - ◆ Before charging a battery pack that is attached to the transceiver, ensure that the safety catch is firmly closed.
 - ◆ While operating the transceiver using a Li-ion or Ni-MH battery pack in areas with an ambient temperature of +14°F/ -10°C and lower, operating time may be shortened.
-

INSTALLING THE (OPTIONAL) ANTENNA

Screw the antenna into the connector on the top of the transceiver by holding the antenna at its base and turning it clockwise until secure.

Note: The antenna is neither a handle, a key ring retainer, nor a speaker/ microphone attachment point. Using the antenna in these ways may damage the antenna and degrade your transceiver's performance.



INSTALLING THE BELT CLIP

If necessary, attach the belt clip using the two supplied 3 x 8 mm screws.

Note: If the belt clip is not installed, its mounting location may get hot during continuous transmission or when left sitting in a hot environment.

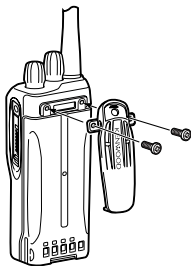

CAUTION

Do not use glue which is designed to prevent screw loosening when installing the belt clip, as it may cause damage to the transceiver. Acrylic ester, which is contained in these glues, may crack the transceiver's back panel.

INSTALLING THE COVER OVER THE UNIVERSAL CONNECTOR

If you are not using the optional KMC-25 speaker/ microphone, install the cover over the universal connector using the supplied 4 x 6 mm screw. Ensure that the cover fits tightly over the connector.

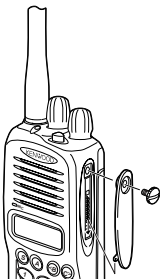

INSTALLING THE (OPTIONAL KMC-25) SPEAKER/ MICROPHONE

- 1 Insert the guide of the speaker/ microphone connector into the groove of the universal connector.
- 2 Secure the connector in place using the attached screw.

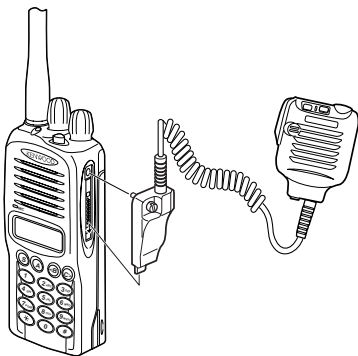

Note: When not using the optional KMC-25 speaker/ microphone, install the cover over the universal connector.

GETTING ACQUAINTED

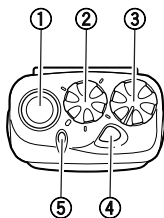

Microphone

Speaker

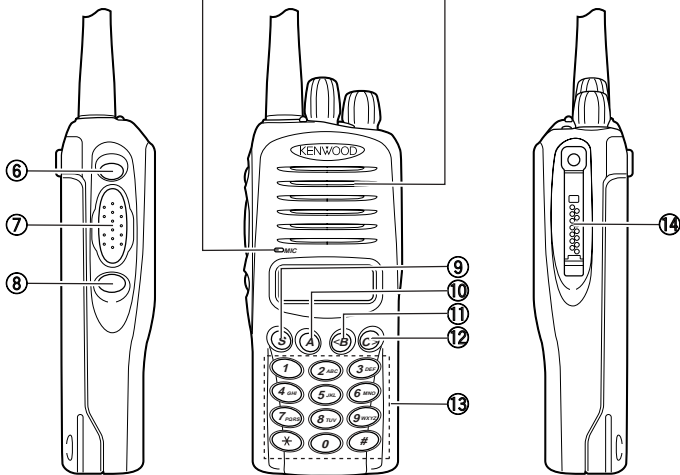

* The transceiver is also available without the DTMF keypad (13).







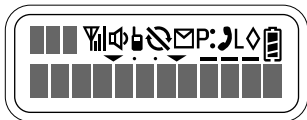

- ① **Antenna connector**
Connect an (optional) antenna here {page 8}.
- ② **Selector**
Rotate to activate its programmable function {page 15}.
The default setting is Zone Up/Down.
- ③ **POWER switch/ VOLUME control**
Turn clockwise to switch ON the transceiver. Rotate to adjust the volume. Turn counterclockwise fully to switch OFF the transceiver.
- ④ **Auxiliary (orange) key**
Press to activate its programmable function {page 15}.
The default setting is None (no function).
- ⑤ **Transmit/ Busy/ Call indicator**
This LED lights red during transmission, green while receiving a call (Conventional operating mode only), and orange when receiving an encoded call (i.e. 2-tone, DTMF signaling, etc.).
- ⑥ **Side 1 key**
Press to activate its programmable function {page 15}.
The default setting is Squelch Off Momentary.
- ⑦ **PTT (Push-To-Talk) switch**
Press this switch, then speak into the microphone to call a station.
- ⑧ **Side 2 key**
Press to activate its programmable function {page 15}.
The default setting is Backlight.
- ⑨ **S key**
Press to activate its programmable function {page 15}.
The default setting is None (no function).
- ⑩ **A key**
Press to activate its programmable function {page 15}.
The default setting is None (no function).

- ⑪ **<B key**
Press to activate its programmable function {page 15}.
The default setting is CH/GID Down.
- ⑫ **C> key**
Press to activate its programmable function {page 15}.
The default setting is CH/GID Up.
- ⑬ **DTMF keypad (keypad models only)**
Press the keys on the keypad to make DTMF calls {page 32} or to activate their programmable functions {page 15}.
- ⑭ **Universal connector**
Connect the (optional KMC-25) speaker/ microphone here {page 9}. Otherwise, keep the supplied cover in place.

DISPLAY



Indicator	Description
	Displays the zone, group ID, and channel numbers. Your dealer can program zone, group ID, and channel names with up to 12 characters, in place of numbers. Also displays received FleetSync messages.
	Displays the zone, group ID, and channel numbers. Also displays list numbers for Operator Selectable Tones.
	Displays the strength of received signals. An antenna and all 3 strength bars represents strong signals while the antenna by itself (no strength bars) represents weak signals.
	Appears when a key programmed as Monitor or Squelch is pressed.
	Appears when the Talk Around function has been activated.
	Appears when you are using Scan mode.
	Flashes when you receive a message. Lights when a message is stored in the stack memory.

Indicator	Description
P:	Appears when the selected channel is programmed as priority. P represents Priority Channel 1, P represents Priority Channel 2, and P: represents Priority Channels 1 and 2.
J	Appears when the selected group is programmed as telephone IDs.
L	Appears when the selected GID or channel is using low transmit power.
◇	Appears when the scrambler function is activated.
	Displays the battery power status. The battery icon and all 3 strength bars represents full power while an empty battery icon represents very low power.
	Appears when the selected zone is added to the scanning sequence.
	Appears when the auto recording function on the VGS-1 option is activated.
	Appears when an Auto Reply Message on the VGS-1 option is activated.
	Appears when the selected group or channel is added to the scanning sequence.
	Appears when the VOX function has been activated.
	Appears when the AUX function has been activated.
	Appears when the OST function has been activated.

PROGRAMMABLE FUNCTIONS

The **Auxiliary**, **Side 1**, **Side 2**, **S**, **A**, **<B**, and **C>** keys {pages 10 to 12} can be programmed with the functions listed below. Please contact your dealer for further details on these functions.

Note: The selector can be programmed as either CH/GID Up/ Down or Zone Up/ Down (default).

- 2-tone
- Autodial
- Autodial Programming
- Auto Reply Message
- Auto Telephone
- AUX
- Backlight (default setting for the **Side 2** key)
- Call 1 ~ Call 6
- CH/GID Down (default setting for the **<B** key)
- CH/GID Recall
- CH/GID Up (default setting for the **C>** key)
- Channel Entry
- Clock
- Direct CH/GID 1 ~ Direct CH/GID 5
- Display Character
- Emergency ¹
- Fixed Volume
- Function
- Home CH/GID
- Key Lock
- Low Transmit Power

- Monitor
- Monitor Momentary
- None
- OST
- Playback
- Scan
- Scan Delete/Add
- Scrambler
- Selcall
- Selcall + Status
- Speaker Attenuation ²
- Squelch Level
- Squelch Off
- Squelch Off Momentary (default setting for the **Side 1** key)
- Status
- Talk Around
- Telephone Disconnect
- Transceiver Password
- VOX
- Zone Down
- Zone Up

¹ “Emergency” can be programmed only on the Auxiliary (orange) key and the PF1 (Programmable Function) key of the optional KMC-25 speaker/ microphone.

² “Speaker Attenuation” can be programmed only on the PF1 and PF2 (Programmable Function) keys of the optional KMC-25 speaker/ microphone.

OVERVIEW

Your dealer can program your transceiver with Trunking and Conventional zones. The transceiver can handle up to 128 zones with up to 250 channels/ group IDs in each zone and a total combined maximum of 512 channels/ group IDs. Zones, channels/ group IDs, and their functions are programmed by your dealer.

SWITCHING POWER ON/ OFF

Turn the **Power** switch/ **Volume** control clockwise to switch the transceiver ON.

- A beep sounds and the display momentarily lights up.
- If the Transceiver Password function is programmed, "PASSWORD" appears on the display. You must enter the password to unlock the transceiver. Refer to "Transceiver Password", below.

Turn the **Power** switch/ **Volume** control counterclockwise to switch the transceiver OFF.

■ TRANSCIVER PASSWORD

To enter the password using the DTMF keypad (keypad models only):

- 1 Press the DTMF keys corresponding to the password digits.
 - Press the **A** or **#** key to delete an incorrect character. Press and hold the **A** or **#** key to delete all entered characters.
- 2 Press the **S** or ***** key to confirm the password.
 - If you enter an incorrect password, an error tone sounds and the transceiver remains locked.

To enter the password without using the DTMF keypad:

- 1 Rotate the selector to select a digit.
- 2 Press the **C>** key to accept the entered digit and move to the next digit.
 - Press the **A** key to delete an incorrect character. Press and hold the **A** key to delete all entered characters.
- 3 Press the **S** key to confirm the password.
 - If you enter an incorrect password, an error tone sounds and the transceiver remains locked.

ADJUSTING THE VOLUME

Rotate the **Power** switch/ **Volume** control to adjust the volume. Clockwise increases the volume and counter-clockwise decreases it.

SELECTING A ZONE AND CHANNEL/ GROUP ID

Select the desired zone using the selector or the keys programmed as **Zone Up/ Zone Down**.

- The default setting for the selector is **Zone Up/ Down**.

Select the desired channel or group ID using the selector or the keys programmed as **CH/GID Up/ CH/GID Down**.

- The default setting for the **<B** key is **CH/GID Down**.
- The default setting for the **C>** key is **CH/GID Up**.

Names can be programmed for zones and channels/ group with up to 12 characters each. However, to fit on the display, names will be abbreviated. Your dealer can set the zone name to a length of 0 to 12 digits. Channel/ group ID names will shorten appropriately, to fit in the 12-digit display.

For example, if the channel/ group ID name is “-CHANNEL1-” and the zone name is “KENWOOD”, and your dealer sets the zone name to 3-digits, the following display will appear:



TRUNKING ZONES

PLACING A DISPATCH CALL

- 1 Select the desired zone and group ID using the selector and the **Zone** or **CH/GID** keys.
- 2 Press and hold the **PTT** switch.
- 3 If the “PTT Proceed” tone sounds, communication is possible; start speaking into the microphone. Release the **PTT** switch to receive.
 - For best sound quality at the receiving station, hold the microphone approximately 1.5 inches (3 ~ 4 cm) from your mouth.
 - Your dealer can deactivate the Proceed PTT tone, if necessary. Ask your dealer for details.

RECEIVING A DISPATCH CALL

- 1 When a dispatch call is received, the transceiver will automatically change to the correct group ID and you will hear the call.
- 2 Readjust the volume as necessary.

PLACING A TELEPHONE CALL

- 1 Select the desired zone and group ID using the selector and the **Zone** or **CH/GID** keys.
 - Alternatively, you can press the key programmed as **Auto Telephone** to automatically search for a Telephone Repeater.
- 2 Press and hold the **PTT** switch for approximately 1 second to ensure a connection.
 - Confirm that there is a dial tone after you release the **PTT** switch.
- 3 Place the call, following the instructions for making a DTMF call, starting on page 32.
- 4 When the called party responds, press the **PTT** switch and speak into the microphone. Release the **PTT** switch to receive.
 - Only one person can speak at a time.
- 5 To end the call, press and hold the **PTT** switch, then press the **#** key or the key programmed as **Telephone Disconnect**.

RECEIVING A TELEPHONE CALL

- 1 When a telephone call is received, the transceiver will automatically change to the correct group ID and you will hear the call.
 - A ringer tone will sound when a call is received.
- 2 Press and hold the **PTT** switch to speak, and release it to receive.
 - Only one person can speak at a time.
- 3 To end the call, press and hold the **PTT** switch, then press the **#** key or the key programmed as **Telephone Disconnect**.

CONVENTIONAL ZONES

TRANSMITTING

- 1 Select the desired zone and channel using the selector and the **Zone** or **CH/GID** keys.
- 2 Press the key programmed as **Monitor** or **Squelch Off** to check whether or not the channel is free.
 - If the channel is busy, wait until it becomes free.
- 3 Press the **PTT** switch and speak into the microphone. Release the **PTT** switch to receive.
 - For best sound quality at the receiving station, hold the microphone approximately 1.5 inches (3 ~ 4 cm) from your mouth.

RECEIVING

- 1 Select the desired zone and channel using the selector and the **Zone** or **CH/GID** keys.
 - Alternatively, you can turn the Scan function on if desired.
- 2 When you hear a caller's voice, readjust the volume as necessary.

QUIET TALK (QT)/ DIGITAL QUIET TALK (DQT)

Your dealer may have programmed QT or DQT signaling on your transceiver channels. A QT tone/ DQT code is a sub-audible tone/ code which allows you to ignore (not hear) calls from other parties who are using the same channel.

When a channel is set up with a QT tone or DQT code, squelch will only open when a call containing a matching tone or code is received. Likewise, signals that you transmit will only be heard by parties whose QT/ DQT signaling matches your transceiver.

If a call containing a different tone or code is made on the same channel you are using, squelch will not open and you will not hear the call. This allows you to ignore (not hear)

these calls. Although it may seem like you have your own private channel while using QT/ DQT, other parties can still hear your calls if they set up their transceiver with the same tone or code.

2-TONE SIGNALING

2-tone Signaling is enabled or disabled by your dealer. This function opens the squelch only when the transceiver receives the 2 tones programmed in your transceiver. Transceivers that do not transmit the correct tones will not be heard.

■ RECEIVING

When you receive a signal containing the correct tones, squelch opens and you will hear the call.

- The LED indicator flashes orange.
- To mute the speaker after squelch opens, press the key programmed as **Monitor**.
- Your dealer can program the squelch to close again after a specific time period elapses.
- If Transpond for 2-tone Signaling is programmed, an acknowledgment signal is returned to the calling station.
- If Call Alert for 2-tone Signaling is programmed, an alert tone will sound when the correct tones are received.

■ TRANSMITTING

- 1 Select your desired zone and channel.
- 2 Press the key programmed as **2-tone**.
- 3 Press the **<B and C>** keys to select the 2-tone code of the station you want to call.
 - Alternatively, you can enter the list number by using the DTMF keypad (keypad models only).
- 4 Press the **PTT** switch and begin your conversation.

Note: If Single Tone has been activated, only the first tone of the 2-tone signal will be transmitted.

OPERATOR SELECTABLE TONE (OST)

You can change the preset encode and decode tones for the selected channel. Your dealer can program up to 40 tones on your transceiver.

To turn OST on or off, press the key programmed as **OST**.

- The OST indicator (■■■■■■■■■■) appears on the display when this function is activated.

To change the preset encode/ decode tones:

- 1 Press and hold the key programmed as **OST** for approximately 1 second.
 - The OST number and name appear on the display.
- 2 Press the **<B** and **C>** keys to select your desired encode/ decode pair.
 - Alternatively, you can enter the list number by using the DTMF keypad (keypad models only).
- 3 Press the **S** key to accept the new setting and return to normal operation.

VOICE OPERATED TRANSMISSION (VOX)

VOX can be activated or deactivated by your dealer. VOX operation allows you to transmit hands-free. This feature can only be used if you are using a supported headset.

When operating VOX, you must set a VOX Gain level. This setting allows the transceiver to recognize sound levels. If the microphone is too sensitive, it will begin transmitting when there is noise in the background. If it is not sensitive enough, it will not pick up your voice when you begin speaking. Be sure to adjust the VOX Gain level to an appropriate sensitivity to allow smooth transmission.

To set the VOX Gain level, perform the following steps:

- 1 Connect the headset to the transceiver.
 - The VOX function does not activate when a headset is not connected to the accessory terminal of the transceiver.

- 2 Press the key programmed as **VOX**.
 - The current VOX Gain level appears.
- 3 Press the **<B and C>** keys to increase or decrease the VOX Gain Level.
 - The VOX Gain can be adjusted from levels 1 to 10.
- 4 While adjusting the gain level, speak into the headset microphone as you would while under normal operation, to test the sensitivity level.
 - When the microphone recognizes a sound, the LED lights orange. This allows you to determine a suitable level where background noise will not activate VOX operation while speaking into the microphone will.
 - The transceiver does not transmit your voice during this test procedure.
- 5 Press the **S** key to save the setting.

To activate the VOX function:

- 1 Connect the headset to the transceiver.
 - The VOX function does not activate when a headset is not connected to the accessory terminal of the transceiver.
- 2 Press and hold the key programmed as **VOX** for 2 seconds.
 - The VOX indicator () appears on the display.
- 3 To turn the VOX function OFF, press and hold the **VOX** key again, for 2 seconds.

Note:



- ◆ If a speaker/ microphone is connected to the transceiver while the VOX function is switched ON and the VOX Gain Level is configured to a higher, more sensitive level, louder received signals may cause the transceiver to start transmission.
 - ◆ When you operate the VOX function, you must use an optional KHS-11BL, KHS-12BL, KHS-14, KHS-15BH, or KHS-15-OH accessory.
-

SCAN

If the Scan function is programmed, zones or channels can be scanned by pressing the key programmed as **Scan**. Scan can be used as either Single Scan, Multi Scan, or List Scan.

- Single Scan monitors only the channels of the currently selected zone, which have been added to the scanning sequence. If set up to scan Priority channels, the Priority channels will be scanned even if they are not within the currently selected zone.
- Multi Scan monitors all channels of every zone, which have been added to the scanning sequence.
- List Scan monitors all channels within the specified range of zones, which have been added to the scanning sequence. If set up to scan Priority channels, the Priority channels will be scanned even if they are not within any of the zones in the list.



To activate Scan, press the key programmed as **Scan**.

- The  icon and "SCAN" or the revert zone and channel/ group ID number appear on the display.
- The zone add indicator () will appear on the display when the selected zone is added to the scan sequence. The channel/ group ID add indicator () will appear on the display when the selected channel/ group ID is added to the scan sequence.
- When a call is received, scanning stops and the zone and channel/ group ID digits appear. Press the **PTT** switch and speak into the microphone to respond to the call. The transceiver will continue scanning after a predetermined time delay if the **PTT** switch is released and no further signal is received.

To stop scanning, press the **Scan** key again.

ADD TO SCAN

Press and hold the key programmed as **Scan Delete/Add**, to add or remove each zone or group ID/ channel to or from the scan sequence.

- The zone add indicator () will appear on the display when the selected zone is added to the scan sequence.
- The channel/ group ID add indicator () will appear on the display when the selected channel/ group ID is added to the scan sequence.

SCAN REVERT

You can select Revert zones and channels/ group IDs using the selector and the **Zone** or **CH/GID** keys.

Eight types of Scan Reverts which can be programmed by your dealer are available.

- **Last Called Revert:** The last zone/ group ID received is assigned as the new revert zone and group ID.
- **Last Used Revert:** The last zone/ group ID responded to is assigned as the new revert zone and group ID.
- **Selected:** The last zone/ group ID selected is assigned as the new revert zone and group ID.
- **Selected + Talkback:** If the zone/ group ID has been changed during Scan, the newly selected zone/ group ID is assigned as the new revert zone and group ID. The transceiver “talks back” on the current receive group ID.
- **Priority 1/ Priority 2:** If your dealer has programmed a Priority channel (either Priority 1 or Priority 2), this channel is the revert zone and channel.
- **Priority 1 + Talkback/ Priority2 + Talkback:** If your dealer has programmed a Priority channel (either Priority 1 or Priority 2), this channel is the revert zone and channel. The transceiver “talks back” on the current receive channel.

Note: “Priority” and “Priority + Talkback” are not available for Trunking Systems.

PRIORITY SCAN

A Priority channel must be programmed in order for Priority Scan to function.

The transceiver will automatically change to the Priority channel when a signal is received on it, even if a signal is being received on a normal channel.

- The P¹ indicator represents the Priority 1 channel.
- The P² indicator represents the Priority 2 channel.
- The P³ indicator represents both the Priority 1 and Priority 2 channel.

Note: Priority cannot be programmed onto the group ID of a Trunking zone; it can be used only on channels of Conventional zones.

GROUP SCAN

Group Scan is useful when more than one channel/ group ID is programmed in a zone. Group Scan is set by your dealer on request. It scans the revert groups as well as groups that are allowed to be scanned.

When a call is received, the group indicator shows the channel/ group ID, and that group becomes the revert group. Simply press the **PTT** switch to respond to the call.

FleetSync is an Alphanumeric 2-way Paging Function, and is a protocol owned by **KENWOOD** Corporation. FleetSync enables a variety of paging functions on your transceiver, some of which depend on dealer programming.

SELCALL (SELECTIVE CALLING)

A Selcall is a voice call to a particular station or to a group of stations.

■ TRANSMITTING

- 1 Select your desired zone and group (or zone and channel).
- 2 Press the key programmed as **Selcall** or **Selcall + Status** to enter Selcall Mode.
- 3 Press the **<B** and **C>** keys to select the ID of the station you want to call.
 - If Manual Dialing is enabled, you can enter digits by using the DTMF keypad or by selecting digits with the selector. When using the selector, rotate it to select a digit, then press the **C>** key to accept the digit and shift the cursor to the right. Repeat this process until the entire ID is entered.
- 4 Press the **PTT** switch and begin your conversation.
 - Alternatively, you can press the **Side 2** key to page the selected station, rather than making a voice call.

■ RECEIVING

An alert tone will sound, the transceiver will automatically enter Selcall Mode, and the calling station's ID will appear when a Selcall is received.

To respond to the call, press the **PTT** switch and speak into the microphone.

■ IDENTIFICATION CODES

An ID code is a combination of a 3-digit Fleet number and a 4-digit ID number. Each transceiver must have its own Fleet and ID number.

- Enter a Fleet number (100 ~ 349) to make a group call.
- Enter an ID number (1000 ~ 4999) to make an individual call in your fleet.
- Enter a Fleet number make a call to all units in the selected fleet (Interfleet call).
- Enter an ID number to make a call to the selected ID in all fleets (Supervisor call).
- Select “ALL” Fleet and “ALL” ID to make a call to all units (Broadcast call).

Note: The ID range may be limited by programming.

STATUS MESSAGE

You can send and receive 2-digit Status messages which may be decided in your talk group. Messages can contain up to 16 alphanumeric characters. Status messages range from 10 to 99 (80 ~ 99 are reserved for special messages).

A maximum of 15 received messages can be stored in the stack memory of your transceiver. These saved messages can be reviewed after reception. Depending on your dealer settings, when the stack memory is full, either the oldest message will be erased when a new message is received or the new message will not be stored in the stack memory. The icon lights when a message is stored in the stack memory.

■ TRANSMITTING

- 1 Select your desired zone and group (or zone and channel).
- 2 Press the key programmed as **Status** to enter Status Mode or **Selcall + Status** to enter Selcall Mode.
 - When using the **Status** key to enter Status Mode, the target Fleet/ ID is fixed and cannot be selected. Skip to step 5 to continue.
- 3 In Selcall Mode, rotate the selector or press the **<B** and **C>** keys to select the ID of the station you want to call.
 - If Manual Dialing is enabled, you can enter digits by using the DTMF keypad or by selecting digits with the selector. When using the selector, rotate it to select a digit, then press the **C>** key to accept the digit and shift the cursor to the right. Repeat this process until the entire ID is entered.
- 4 Press the **S** key to enter Status Mode.
- 5 Rotate the selector or press the **<B** and **C>** keys to select the status ID you want to transmit.
 - If Manual Dialing is enabled, you can enter digits by using the DTMF keypad or by selecting digits with the selector. To enter manual input mode, first press and hold the **S** key. When using the selector, rotate it to select a digit, then press the **C>** key to accept the digit and shift the cursor to the right. Repeat this process until the entire ID is entered.
- 6 Press the **PTT** switch or **Side 2** key to initiate the Status call.
 - “«COMPLETE»” is displayed when the call has been successfully transmitted.

■ RECEIVING

The ☑ icon will flash and a calling ID or text message will appear when a Status call is received.

Press any key to return to Normal Operation Mode.

■ REVIEWING MESSAGES IN THE STACK MEMORY

- 1 Press and hold the key programmed as **Selcall**, **Status**, or **Selcall + Status** for 1 second to enter Stack Mode.
 - The last received message is displayed with the message number.
- 2 Rotate the selector or press the **<B** and **<C>** keys to select the desired message.
 - Press and hold the **S** key to toggle between the message/call ID, the channel name, and the time of the received message.
- 3 Press the **S** key to return to Normal Operation Mode.
 - To delete the selected message, press the **A** or **#** key. To confirm the deletion, press the **S** or ***** key.
 - To delete all messages, press and hold the **A** or **#** key for 1 second. To confirm the deletion, press the **S** or ***** key.

SHORT MESSAGES

To send a short message, you must connect the transceiver to a PC. Ask your dealer for details.

- Short messages can contain a maximum of 48 characters.
- Received short messages are displayed the same as Status messages and are stored in the same stack memory. A combined maximum of 15 Status calls and short messages can be stored in the stack memory.

LONG MESSAGES

To send and receive long messages, you must connect the transceiver to a PC. Ask your dealer for details.

- Long messages can contain a maximum of 4096 characters.

MANUAL DIALING (KEYPAD MODELS ONLY)

■ METHOD 1

Press and hold the **PTT** switch, then enter the desired digits using the front panel keypad.

- If you release the **PTT** switch, transmit mode will end even if the complete number has not been sent.
- If your dealer has activated the Keypad Auto PTT function, you need not press the **PTT** switch while pressing the keys on the keypad in Conventional systems. The DTMF code will be sent automatically when you press a key.

Note: Keypad Auto PTT does not function in Trunking systems.

■ METHOD 2

Enter the desired digits using the front panel keypad (maximum of 30 digits). After entering the complete number, press the **PTT** switch.

- In Conventional systems, the DTMF code is transmitted after pressing the **PTT** switch.
- In Trunking systems, the DTMF code is transmitted after a connection is established. Releasing the **PTT** switch before a connection is established will stop the transmission from occurring.
- In RIC (Repeater Inter-Connect) Trunking systems, the DTMF code is transmitted after a connection with the telephone system is established. Press the key programmed as **Autodial** (instead of the **PTT** switch) to automatically connect to the repeater and transmit the DTMF code.

Note: If you switch the power OFF before sending the number, the number will be cleared from memory.

STORE AND SEND

Store and send allows you to make DTMF calls without the need for a DTMF keypad.

- 1 Press the key programmed as **Autodial**.
 - “CODE?” appears on the display.
- 2 Rotate the selector to select a digit.
 - Alternatively, you can enter the digits by using the DTMF keypad (keypad models only).
- 3 Press the **C>** key to accept the entered digit and move to the next digit.
 - Press the **A** or **#** key to delete an incorrect character. Press and hold the **A** or **#** key to delete all entered characters.
 - You can enter up to 30 digits.
- 4 Press the **PTT** switch to make the call after the entire number is entered.

AUTODIAL

Autodial allows you to store 32 names (up to 12 characters per name) and DTMF numbers (up to 16 digits per number).

■ STORING DTMF NUMBERS

- 1 Press the key programmed as **Autodial Programming**.
 - The first entry in the Autodial list appears on the display.
- 2 Rotate the selector, press the **<B** and **C>** keys, or press the appropriate DTMF key (01 ~ 32) to select your desired Autodial list number.
- 3 Enter the desired name using the selector or keypad. Rotate the selector or press the keypad to select a character, then press the **C>** key to confirm the character and move the cursor to the right. Repeat this operation until the complete name is entered, then press the **S** key to confirm the entry.

- Press the **A** or **#** key to delete an incorrect character. Press and hold the **A** or **#** key to delete all entered characters.
 - “CODE?” appears on the display after confirming the entered name.
- 4 Enter the desired number using the DTMF keypad or the selector. When using the DTMF keypad, simply enter the desired number, followed by the **S** key to confirm the entry. When using the selector, rotate the selector to select a digit, then press the **C>** key to confirm the digit and move the cursor to the right. Repeat this operation until the complete number is entered, then press the **S** key to confirm the entry.
 - Press the **A** or **#** key to delete an incorrect character. Press and hold the **A** or **#** key to delete all entered characters.
 - “STORE?” appears on the display after confirming the entered number.
 - 5 Press the **S** or ***** key to store the entered name and number in the Autodial list.
 - Press the **A** or **#** key to cancel the entry.
 - If you are overwriting a previous entry, “OverWrt.?” appears on the display. Press the **S** or ***** key to overwrite the entry, or press the **A** or **#** key to cancel.

■ DIALING STORED DTMF NUMBERS

- 1 Press the key programmed as **Autodial**.
 - The first entry in the Autodial list appears on the display.
- 2 Rotate the selector, press the **<B** and **C>** keys, or press the appropriate DTMF key (01 ~ 32) to select your desired Autodial list number.
 - The stored entry appears on the display.
- 3 Press the **PTT** switch to make the call.

■ CLEARING STORED DTMF NUMBERS

- 1 Press the key programmed as **Autodial Programming**.
- 2 Rotate the selector, press the **<B** and **C>** keys, or press the appropriate DTMF key (01 ~ 32) to select your desired Autodial list number.
- 3 Press the **A** or **#** key.
 - “DELETE?” appears on the display after confirming the entered number.
- 4 Press the **S** or ***** key to delete the entry from the Autodial list.
 - The selected memory location is cleared.

REDIAL (KEYPAD MODELS ONLY)

You can redial the last number you transmitted.

- 1 Press the key programmed as **Autodial**.
 - The first entry in the Autodial list appears on the display.
- 2 Press the ***** key followed by the **0** key to display the last called number.
- 3 Press the **PTT** switch to make the call.

Note: Switching OFF the transceiver power clears the redial memory.

CONNECT/ DISCONNECT IDs (KEYPAD MODELS ONLY)

- 1 Press the key programmed as **Autodial**.
 - The first entry in the Autodial list appears on the display.
- 2 Connect ID: Press the ***** key two times.
Disconnect ID: Press the ***** key followed by the **#** key.
- 3 Press the **PTT** switch to make the call.

DTMF SIGNALING

DTMF Signaling is either enabled or disabled by your dealer. This function opens the squelch only when the transceiver receives the DTMF code programmed in your transceiver. Each transceiver is normally programmed with a unique code. You will not hear calls from transceivers that are not programmed with a matching code.

When you receive a signal containing the correct tones, squelch opens and you will hear the call.

- The LED indicator flashes orange.
- To mute the speaker after squelch opens, press the key programmed as **Monitor**.
- Your dealer can program the squelch to close again after a specific time period elapses.
- If Transpond for DTMF Signaling is programmed, an acknowledgment signal is returned to the calling station.
- If Tone Alert for DTMF Signaling is programmed, an alert tone will sound when the correct tones are received.

STUN

This function is used when a transceiver is stolen or lost. When the transceiver receives a call containing a stun code, either transmit mode will be disabled, or both receive mode and transmit mode will be disabled. Stun is cancelled when the transceiver receives a call with a revive code.

EMERGENCY CALLS

If your transceiver has been programmed with the Emergency function, you can make emergency calls.

Note: Only the Auxiliary (orange) key and the PF1 (Programmable Function) key of the optional KMC-25 speaker/ microphone can be programmed with the Emergency function.

- 1 Press and hold the key programmed as **Emergency**.
 - Depending on the delay time programmed into your transceiver, the length of time you must hold the **Emergency** key will vary.
 - When the transceiver enters Emergency mode, the transceiver will change to the Emergency channel and begin transmitting based on how the transceiver is set up by your dealer. Transmit periods are also set by your dealer.
- 2 To exit Emergency mode, press and hold the **Emergency** key again.
 - If the Emergency mode completes the preset number of cycles, Emergency mode will automatically end and the transceiver will return to the channel that was in use before Emergency mode was entered.

Note:

- ◆ Your dealer can set the transceiver to emit a tone when Emergency mode starts and stops
 - ◆ Your dealer can set the transceiver to emit tones and received signals as normal or mute the speaker during Emergency operation.
-

SELECTING A TRANSMIT POWER

Each channel is programmed with either high or low transmit power by your dealer. You can change the transmit power of only channels programmed as high.

When you can reliably communicate with other parties without using high transmit power, select low transmit power by pressing the key programmed as **Low Transmit Power**. Each time you press **Low Transmit Power**, the transmit power toggles between high and low.

- The **L** icon appears while using low transmit power.
- Using low transmit power conserves battery power and reduces the risk of interfering with other communications.

Note: Pressing **Low Transmit Power** while using a channel programmed with low transmit power causes an error tone to sound.

TALK AROUND

You may occasionally experience an interruption in service (due to a power failure, etc.). During such an occurrence, you can continue communication by using the Talk Around feature. Talk Around allows you to communicate directly with other transceivers, without the use of a repeater. However, if the station you want to contact is too far away, or there are geographical obstacles in the way, you may not be able to contact the station.

Toggle Talk Around ON and OFF by pressing the key programmed as **Talk Around**.

- The **T** icon appears on the display while Talk Around is active.
- When using Talk Around, the receive frequency is used for both transmitting and receiving, and the decode signaling is used for both encoding and decoding.

MONITOR/ SQUELCH OFF

You can use the key programmed as **Monitor/ Squelch Off** to listen to weak signals that you cannot hear during normal operation and to adjust the volume when no signals are present on your selected channel.

- The  icon appears on the display while Monitor/ Squelch Off is activated.

Note: Squelch Off can be used only in Conventional operating mode.

Your dealer can program a key with one of 4 functions:

- **Monitor Momentary:** Press and hold to deactivate QT, DQT, DTMF, 2-tone, or FleetSync Signaling. Release the key to return to normal operation.
- **Monitor:** Momentarily press to deactivate QT, DQT, DTMF, 2-tone, or FleetSync Signaling. Press the key again to return to normal operation.
- **Squelch Off Momentary:** Press and hold to hear background noise. Release the key to return to normal operation.
- **Squelch Off:** Momentarily press to hear background noise. Press the key again to return to normal operation.

■ SQUELCH LEVEL

To adjust the squelch level in Conventional operating mode:

- 1 Press the key programmed as **Squelch Level**.
- 2 Press the **<B** key to decrease the squelch level (open) and the **C>** key to increase the squelch level (tighten).
 - Alternatively, you can increase or decrease the squelch level by rotating the selector.
- 3 Press the **S** key to store the new setting and exit the squelch level adjustment.

KEY LOCK

This function is used to help prevent any accidental operation of the transceiver.

To lock the transceiver keys, press and hold the key programmed as **Key Lock** for 1 second.

- “LOCKED” appears on the display.
- You can continue to use the following programmable functions (if available): **Emergency, Function, Key Lock, Backlight, Monitor, Monitor Momentary, Squelch Off, and Squelch Off Momentary.**

To unlock the keys, press and hold the **Key Lock** key again for 1 second.

SCRAMBLER

Although the scrambler function does not offer complete privacy with your calls, it does prevent others from easily listening in on your calls. When activated, the transceiver distorts your voice so that anybody listening to your conversation will not be able to clearly hear what you are saying.

In order for members of your own group to clearly hear your call while you are using the scrambler, all other members must also activate the scrambler functions on their transceivers. This distorts everybody's voice while transmitting and corrects the voice message on your own transceiver when you receive the call.

To activate the scrambler, press the key programmed as **Scrambler**.

- The \diamond icon appears on the display while the scrambler is active.

To deactivate the scrambler, press the **Scrambler** key again.

Note: There are 2 options for using the scrambler. Your dealer can activate or deactivate the built-in scrambler function of the transceiver, or they can add a more secure optional scrambler board to your transceiver. Ask your dealer for details.

CLOCK

If activated by your dealer, your transceiver can track the time and date with its built-in clock. The time will display momentarily when the transceiver power is turned ON. Additionally, you can view the clock any time by pressing the key programmed as **Clock**.

Note: Removing the battery pack or leaving the battery pack uncharged for extended periods will cause the clock time to clear.

■ CLOCK SETUP

To set the year, month, day, and time:

- 1 With the transceiver power OFF, press and hold the **C>** key while turning the transceiver power ON.
 - The current year setting appears.
- 2 Rotate the selector to select the year, then press the **S** key to cycle to the month setting.
 - Repeat this step, to cycle through the day, hour, and minute settings.
- 3 Press the **S** key again, to return to the year setting.
 - A triple beep will sound, indicating that your selections have been set into the transceiver memory.
- 4 Turn the transceiver power OFF and then back ON to return to Normal Operation Mode.

BACKLIGHT

To turn the transceiver display backlight on, press the key programmed as **Backlight**.

- Pressing any key other than the **PTT** switch and the **Power** switch/ **Volume** control while the backlight is on will reset the lamp timer, allowing the backlight to remain lit for an additional 5 seconds.

To turn the display backlight off immediately, press the **Backlight** key while the backlight is on.

BACKGROUND OPERATIONS

TIME-OUT TIMER (TOT)

The purpose of the Time-out Timer is to prevent any caller from using a channel for an extended period of time.

If you continuously transmit for a period of time that exceeds the programmed time set by your dealer (default is 1 minute for Conventional and dispatch (Trunking) operation, and 3 minutes for telephone (Trunking) operation), the transceiver will stop transmitting and an alert tone will sound. To stop the tone, release the **PTT** switch.

Your dealer can program the TOT time in the range of 15 seconds to 20 minutes for Conventional operation and 15 seconds to 10 minutes for Trunking operation.

BUSY CHANNEL LOCKOUT (BCL)

When activated, BCL prevents you from interfering with other parties who may be using the same channel that you selected, in Conventional operating mode. Pressing the **PTT** switch while the channel is in use will cause your transceiver to emit an alert tone and transmission will be inhibited (you cannot transmit). Release the **PTT** switch to stop the tone and return to receive mode.

If activated, you can override this function. To override BCL, press the **PTT** switch again immediately after releasing it (within half a second).

Note: Ask your dealer for an explanation on how BCL functions when using QT, DQT, DTMF, 2-tone, or FleetSync signaling.





BATTERY SAVER

If activated by your dealer, the Battery Saver function will decrease the amount of power used when a signal is not being received and no operations are being performed (no keys are being pressed, and no switches are being turned).

While the channel is not busy and no operation is performed for 5 seconds, Battery Saver turns ON. When a signal is received or an operation is performed, Battery Saver turns OFF.

BATTERY POWER INDICATOR





The battery power indicator displays the battery power remaining, as illustrated below:

-  High power
-  Medium power
-  Low power
-  Very low power

When the transceiver power is very low, replace or recharge the battery pack. If activated by your dealer, an alert tone will sound every 30 seconds and the LED indicator will blink red when the battery power is low.

SIGNAL STRENGTH INDICATOR

The signal strength indicator displays the strength of received calls:

-  Strong signal
-  Medium signal
-  Weak signal
-  Very weak signal

BEGINNING/ END OF TRANSMIT SIGNAL

The Beginning of Transmit and End of Transmit identification signals are used to access and release some repeaters and telephone systems.

If Beginning of Transmit is set, the ID signal is transmitted when you press the **PTT** switch.

If End of Transmit is set, the ID signal is transmitted when you release the **PTT** switch.

If both are set, the ID signal is transmitted when you press and release the **PTT** switch.

When using the optional VGS-1 voice guide & storage unit, you gain access to the voice recorder and voice announcement functions. Ask your dealer for details.

VOICE RECORDER

The voice recorder function allows you to record your conversations and create voice memos and automated message responses.

■ AUTO RECORDING

If activated, the auto recording function will continuously record all transmitted and received signals. The recording storage area retains 30 seconds of recording, so all transmitted and received signals are simultaneously recorded and erased, leaving only the last 30 seconds of recording in memory.

- The auto recording indicator () appears when this function is activated.

■ VOICE MEMOS

To record a voice memo, for later playback:

- 1 Press and hold the key programmed as **Playback** for 1 second.
 - The duration of recording memory will appear on the display and begin counting down.
- 2 Speak into the transceiver to record your voice memo.
- 3 Press the **Side 2** key to end the recording at any time and store it into the transceiver memory.
 - If the memory becomes full, recording will stop automatically and store the voice memo to memory.
 - "WRITING" appears on the display while the recording is being stored to memory.

■ AUTO REPLY MESSAGE

You can set the transceiver to automatically respond to Individual Calls (while using FleetSync):

- 1 Press the key programmed as **Auto Reply Message** to enter Auto Reply Message mode.
 - The Auto Reply Message indicator (■■■■■■■■■■) appears on the display.
- 2 When you receive an Individual Call, Auto Reply will begin after waiting for 3 seconds, the transceiver will send an automatic response to the caller, and "GREETING" appears on the display.
 - If you are available to receive the call, press any key to disable the auto response.
 - If there is a channel available on your transceiver for recording, "I am not available. Leave your Message." will be sent to the caller. The caller can then leave a recorded message on your transceiver which you can later recall and listen to. When a message is stored on your transceiver, "Msg Rcvd" appears on the display.
 - If there is no channel available on your transceiver for recording, "I am not available." will be sent to the caller and "MEMORY FULL" appears on the display.

■ PLAYBACK

To play back a recorded conversation, memo, or message:

- 1 Press the key programmed as **Playback** to enter Playback mode.
 - If the last action on your transceiver was to auto record your conversation, "STORE?" will appear on the display, otherwise a recording channel with the time of the recording will appear. To store the conversation record in the next available recording channel, press the **Side 2** key. To clear the conversation, press the **A** or **#** key. To skip to the stored recording channels, press the **S** or ***** key. To skip back 5 seconds, press the **<B** key. To skip ahead 5 seconds, press the **C>** key.
- 2 Rotate the selector to select the channel which you want to play back.
 - "RM" represents automated reply messages.
 - "RR" represents conversation records.
 - "UM" represents voice memos.
- 3 The transceiver will announce the channel, then the recording will automatically play back.
 - When the entire recording has been played, "END OF MSG" (end of message) is displayed.
 - To delete the selected recording, press the **A** or **#** key. To clear all the recorded data, press and hold the **A** or **#** key. A confirmation message will appear on the display. Press the **S** or ***** key to delete the recording(s) or the **A** or **#** key to cancel.

VOICE GUIDE

When changing the zone, group ID, channel, or operation mode, an audio voice will announce the new zone, group ID, channel, or mode, after it has been selected. (Voice Annunciation can be activated or deactivated by your dealer.)